



# **REQUEST FOR PROPOSAL**

## **138kV Transmission Poles Steel Poles**

for

Rochelle Municipal Utilities  
Rochelle, IL 61068

By

**BHMG Engineers, Inc.**

December 15, 2014

## **Overview:**

BHMG Engineers, Inc. is requesting proposals on behalf of Rochelle Municipal Utilities for the design, materials, welding, inspection, protective coatings, drawings, and delivery of 6 direct embedded steel poles and 1 self-supported steel dead-end pole. The proposal submitted by the manufacturer shall include field bolts, locknuts, vangs, attachment provisions for insulators and crossarms, anchor bolts, base plates, and other necessary items to make a complete structure.

## **Transmission Pole Specification**

### Part 1 - GENERAL

#### 1.1 QUALITY ASSURANCE

- A. All materials, equipment, sizes, and capacities shall conform to the requirements of the National Electrical Code, the National Electrical Manufacturers Association, and prevailing state and local codes.
- B. All materials shall be UL labeled.

#### 1.2 REFERENCE STANDARDS

- A. American Society of Civil Engineers (ASCE) Standard, Design of Steel Transmission Pole Structures, Manual 72, latest edition.
- B. American Society for Testing and Materials (ASTM), various standards, latest revision.
- C. American Concrete Institute (ACI), Building Code Requirements for Reinforced Concrete, ACI 318, latest edition.
- D. American Welding Society (AWS), Structural Weld Code, AWS D1.1, latest edition.
- E. American National Standards Institute (ANSI), National Electrical Safety Code, ANSI C2, latest edition.
- F. Society for Protective Coatings (SSPC), Surface Preparations Specification, SSPC SP-6.

#### 1.3 SUBMITTALS

- A. Information to be supplied with the proposal:
1. Calculated shipping weights of each structure excluding anchor bolts.
  2. Calculated shipping weight for anchor bolts.
  3. Ultimate groundline reactions (including load factors) in poles.
  4. Description of pole shaft, including thickness, length, diameter, cross-sectional geometry, and method of fastening each shaft component.
  5. Draft drawings of structure and structure attachments.
- B. Information to be supplied after receipt of order:
1. Erection Drawings shall include:
    - a. A bill of material of all components to be assembled.
    - b. A drawing showing location of components for assembly.
    - c. Identification markings
    - d. Assembly information
    - e. Component weights
    - f. Allowable tolerances for any slip joint connections.
  2. Shop drawings shall include:
    - a. Detailed drawings for each structure type giving weights of structure, components, dimensions, and bill of material.
    - b. All surface preparation and finishing information.
    - c. Allowable tolerances for any slip joint connections.
  3. PLS-Pole model for any self-support structure supplied.

## Part 2 - PRODUCTS - TRANSMISSION POLES

### 2.1 DESIGN

- A. Stress calculations shall be the responsibility of the fabricator. Loadings and limitations are provided elsewhere in the proposal document.
- B. The maximum design unit stress shall be minimum yield strength as stated in the applicable ASTM specifications for the particular application and types of loads, including load factors.
- C. Stress calculations shall be based on elastic analysis with maximum stresses in main members being limited to the specific yield strength of the

steel being used.

- D. Stability shall be provided for the structure as a whole and for each structural element. The nonlinear effects of the structure in its deflected position shall be considered.
- E. Poles shall be designed with a minimum number of joints. Field welding shall not be allowed as part of the design of a new pole. The shaft joints to be made in the field shall be slip joints or bolted flange joints. Slip joints length shall be at least 1.5 times the largest inside diameter of the female section.
- F. The manufacturer shall verify slip joints fit before shipment. Joints should not interfere with step nuts, ladder clips, or jacking nuts.
- G. Sufficient jacking lugs and permanent orientation marks shall be provided at all slip joints to ensure proper alignment and complete overlap of the joint.
- H. Manufacturer shall provide any special tools that are required to assembly slip joint poles.
- I. The thickness for any tubular member shall not be less than 3/16 inch.
- J. Anchor bolts shall have the top 2' galvanized. Anchor bolts shall be threaded at the top end, a distance equal to the baseplate thickness plus the thickness of two anchor bolt butts plus 2.5". Each anchor bolt shall include two heavy hex nuts.
- K. Structures which are direct embedded shall have bearing plates and ground sleeves. Bearing plates shall have a diameter not more than 2" greater than the maximum pole diameter.
- L. The ground sleeve shall have a minimum thickness of 3/16" and shall be centered at the groundline. A seal weld shall be provided around the ground sleeve. The ground sleeve shall not be considered in strength calculations.
- M. Poles shall have nearly a uniform taper throughout their entire length. The maximum difference in tapers between two pole sections measured by the diameters shall be 0.20 inch/ft. for poles with variable taper.
- N. All unguyed angle poles and unguyed tangent deadends shall be precambered to remain plumb when the calculated deflection at the top of the pole exceeds 1.5% of the pole height under an initial conductor tension loading of 60°F, no wind, and no load factors.

- O. The manufacturer shall supply all instructions for handling and erection of poles.
- P. In the design of connections for vangs, brackets, and stiffeners attached to the pole shaft, care shall be taken to distribute the loads sufficiently to protect the wall of the pole from local buckling.
- Q. Each pole shall be permanently marked on the pole shaft 60" above groundline and on the bottom of the baseplate or bearing plate with the following identifying information: structure number, owner name, and date manufactured. The method of identification shall be approved by the owner.

## 2.2 MATERIALS

- A. All material shall comply with the requirements of an ASTM specification unless otherwise specified.
- B. Thicknesses  $\leq 1.25$ " : Structural plate less than or equal to 1.25" in thickness shall conform to ASTM A36, ASTM 572 or ASTM A871.
- C. Thicknesses  $> 1.25$ " : Structural plate greater than 1.25" in thickness shall conform to ASTM A36, ASTM A572, ASTM A588, ASTM A633 or ASTM A871.
- D. Anchor Bolts: Material shall conform to ASTM A615 Gr 75.
- E. Nuts: Nuts shall conform to ASTM A563.
- F. Washers: Washers shall conform to ASTM F436.
- G. Anchor bolts, structural plate, and weld material, shall meet ASCE requirements for Charpy tests.
- H. The material used for making welds shall be compatible with the parent material, as defined by ANSI/AWS D1.1-92.

## 2.3 FABRICATION

- A. All welding shall be in accordance with the AWS D1.1, latest edition. Welders shall be qualified in accordance with AWS D1.1 welding procedures.
- B. All penetration welds shall be required in, but not limited to, the following areas:

1. Circumferential welds (C-welds) joining structural members.
  2. Longitudinal welds in the female portion of the joint within the slip joint area.
  3. Welds at the butt joints of the back-up strips.
  4. Base plate to shaft welds.
  5. Longitudinal welds for a minimum length of 3" where there are adjacent C-welds, flange welds, base welds, and end of tubes.
- C. Full penetration or equivalent 90% partial penetration with fillet overly shall be used for the arm-to-arm base, vang-to-plate shaft, and arm box joints.
- D. Field welding shall not be permitted except with owners' approval and the manufacturer's direction in repairing a pole.
- E. Edges shall be in accordance with ANSI/AWS D1.1. Burrs or sharp notches that may be detrimental to the structure or that pose a safety hazard shall be removed. Re-entry cuts shall be rounded.
- F. Care shall be taken to prevent separation of the outer surface and reduction of the cross sectional properties below those required by design. If separation occurs during bending, it shall be repaired in accordance with ANSI/AWS D1.1. Mill scale shall not be considered as the surface. When hot bending is required; heating shall be done evenly over the entire bend area and shall be of sufficient temperature to minimize separation and necking down of the cross section. The temperature used in hot bending shall be such that the physical properties of the steel are not diminished.

## 2.4 PROTECTIVE COATINGS

### A. Weathering Steel

1. The structure shall be designed to eliminate water and refuse traps.
2. Tubular sections shall be sealed to eliminate the need for internal corrosion protection.

### B. Coating for Embedded Steel

1. Poles that are directly embedded must have a 16 mil (minimum dry film thickness), two components hydrocarbon extended polyurethane coating that is resistant to ultraviolet light shall be applied to the exposed surface of the embedded portion of the pole.

The coating will extend from the butt to the top of the ground sleeve.

## 2.5 TOLERANCES

### A. Pole Length

1. One Piece -  $\pm 2"$  or  $1" \pm 1/8"$  per 10 feet of length, whichever is greater.
2. Slip Joint connection -  $-6"$  or  $+12"$

### B. Pole Diameter

1.  $-0"$  or  $+1/4"$

### C. Pole End Squareness

1.  $\pm 1/2"$  per foot of pole diameter

### D. Pole Sweep

1.  $1/8"$  per 10 feet of pole length

### E. Pole Twist

1. None accepted

### F. Location of Group of Bolt Holes from Top of Pole

1.  $\pm 1"$

### G. Location of Centerlines between Groups of Bolt Holes

1.  $\pm 1"$

### H. Location of Holes within Groups of Bolt Holes

1.  $\pm 1/8"$

## 2.6 GROUNDING

- A. Pole grounding connections shall be welded to the pole shaft, 18" above the groundline and 18" below the top of the pole. The grounding connections can be a two-hole NEMA pads or threaded inserts installed in the pole.

- B. The grounding pad shall not be covered with coating. The grounding nut thread and grounding pad threads shall be protected from coatings.

## Part 3 - EXECUTION

### 3.1 INSPECTIONS AND TESTING

- A. The owner and the owner's designated agents shall have free entry at all time while work is being carried on, to all parts of the manufacturer's plant to inspect any part of the production of the poles covered by this specification.
- B. The cost of tests made by the manufacturer (except full scale load tests on poles), including cost of the certified test reports shall be considered included in the price.
- C. Inspection personnel performing nondestructive examinations (other than visual) shall be qualified in accordance with ASNT Practice No. SNT-TC-1A.
- D. Each component shall be inspected for conformance to the fabrication drawings. This inspection shall include, but not be limited to:
  - 1. Ultrasonic inspection of all base plate material prior to welding for laminations.
  - 2. Visual inspection of dimensions to assure that tolerances are met.
  - 3. Visual inspection of cut edges to ANSI/AWS D1.1 criteria.
  - 4. Visual inspection of bent surfaces for surface separations (supplemented by mag particle in questionable areas).
  - 5. Visual inspection of bolt holes to assure that they are cylindrical, perpendicular, free of burrs, and without torn or ragged edges.
  - 6. Visual inspection of all welds to ANSI/AWS D1.1 Section 8 criteria.
  - 7. Ultrasonic inspection of all full penetration welds.
  - 8. Ultrasonic inspection of shaft to base plate welds after galvanizing (may be waived if routine audits show no history of defects).
  - 9. Magnetic particle inspection of all structural partial penetration or fillet welds to ANSI/AWS D1.

10. Visual inspection of finish.
11. Magnetic thickness measurements of finish coatings.

E. Load Application

1. The test structure shall be subjected to 100% of all governing loading conditions with incremental readings of 50%, 75%, and 90%. The sequence of testing shall be determined by the structure designer and approved by the Owner.
2. Conductor and shield wire loads shall be applied to the actual points of conductor and shield wire attachments to the structure. Window load may be added to the shield wire or conductor loads or be applied at points along the pole shaft.
3. Loads shall be applied in a manner to avoid impact on the pole. The 100% load increment shall be held for a period of not less than five minutes.

F. Load Measurement

1. All applied loads shall be measured by a system of load cells, dynamometers or the direct application of weights. The system used shall be such that pulley friction has no effect on load readings.
2. All load measuring devices shall be used in accordance with the device manufacturer's recommendations. Satisfactory evidence of the accuracy of the load measuring devices shall be included in the test report.
3. Structure deflections under load shall be measured and recorded. Points to be monitored shall be selected so as to verify deflections predicted by the design analysis. Deflection readings shall be made at the before-load and load-off conditions as well as all intermediate hold points.

G. Inspection

1. Following application of each load case, a visual inspection of all structure components shall be made by the fabricator and/or the Owner.

2. The structure shall be considered as acceptable if none of the members or bolts have an obvious permanent set.
3. After successful completion of the acceptance test, the structure shall be disassembled and all welds inspected to the same criteria as required during the original fabrication.

### 3.2 SHIPPING

- A. All structures shall be shipped F.O.B. destination and staked dropped according to drawing provided by owner.
- B. Each shipment shall be accompanied by a list of all parts, identifiable by structure type and number. All parts required for any one structure shall be in one shipment, if possible.
- C. The owner and owner's representative shall be notified prior to shipment that such shipment is to take place, and they reserve the right to inspect the components prior to shipment. The notification shall give quantities, weights, name of common carrier used, and expected time of arrival.
- D. The anchor bolts shall be welded to the holding plate in the bottom of the cage. A removable template shall be used at the top of the cage and shall be marked to show the centerline for tangent structures and the angle bisector for angel structures. Matching marks are to be on the base plate so proper alignment can be made. Bolt clusters shall be rigid enough to withstand the normal jolts of shipping and handling with no displacement of bolts from the proper positions within the cluster.
- E. Unless otherwise agreed to by the owner, the anchor bolt cage shall be shipped at least 30 days prior to pole shipment.

### Part 4 - ATTACHMENTS

- 4.1 DIRECT EMBEDDED POLE DRAWING/DESIGN CRITERIA (TP-138D)
- 4.2 SELF-SUPPORT ENGINEERED DEADEND DRAWING/DESIGN CRITERIA (STR# 03727)

## **RFP Schedule:**

RFP Issued	December 16, 2014
Proposals Due	December 30, 2014 @ 11:00am CST
Award Date	January 6, 2015
Required Delivery Date	April 24, 2015

## **Proposal Breakdown:**

Pole Height (feet)	Pole Class	Quantity	Unit Price(\$)	Total Price (\$)
90	LD2	2		
90	LD3	1		
90	LD4	2		
90	LD5	1		
80	Engineered Self-Supported	1		
			<b>Total Base Bid</b>	

Additional Units (In addition to those indicated in the specification)	Bid Price Per Unit (\$)
Bolt hole drilled in pole	
10 kip Vang	
Ground Lug	
Distribution Arm per Detail on Drawing STR# 03727	

## **Submitted by:**

Company Name: \_\_\_\_\_

Name (typed or printed): \_\_\_\_\_

Date: \_\_\_\_\_

*All RFP correspondence and proposals shall be sent electronically to Lukas Pirok at [lpirok@bhmg.com](mailto:lpirok@bhmg.com) per the scheduled dates above. Hard copies of the proposal are not required.*

Embedment Transmission Structures				
Structure Number	Height (ft)	Class	GL Moment (ft-kips)	Embedment(ft)
03738	90	LD2	267	16
03736	90	LD2	267	16
03734A	90	LD3	317	16
03733	90	LD4	372	16
03732	90	LD4	372	16
03729	90	LD5	457	16

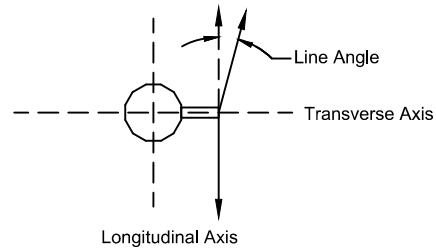

Static Plan View

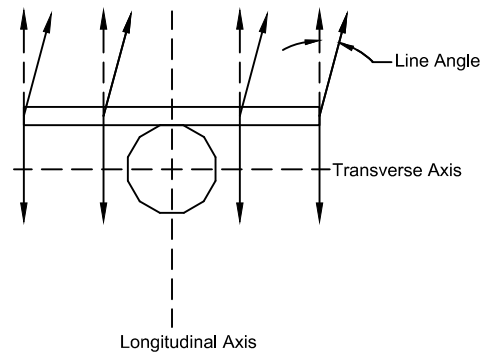

Distribution Plan View

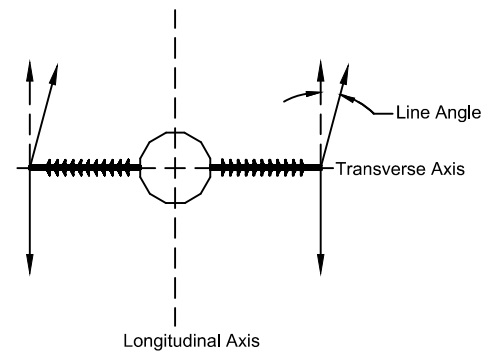

Transmission Plan View

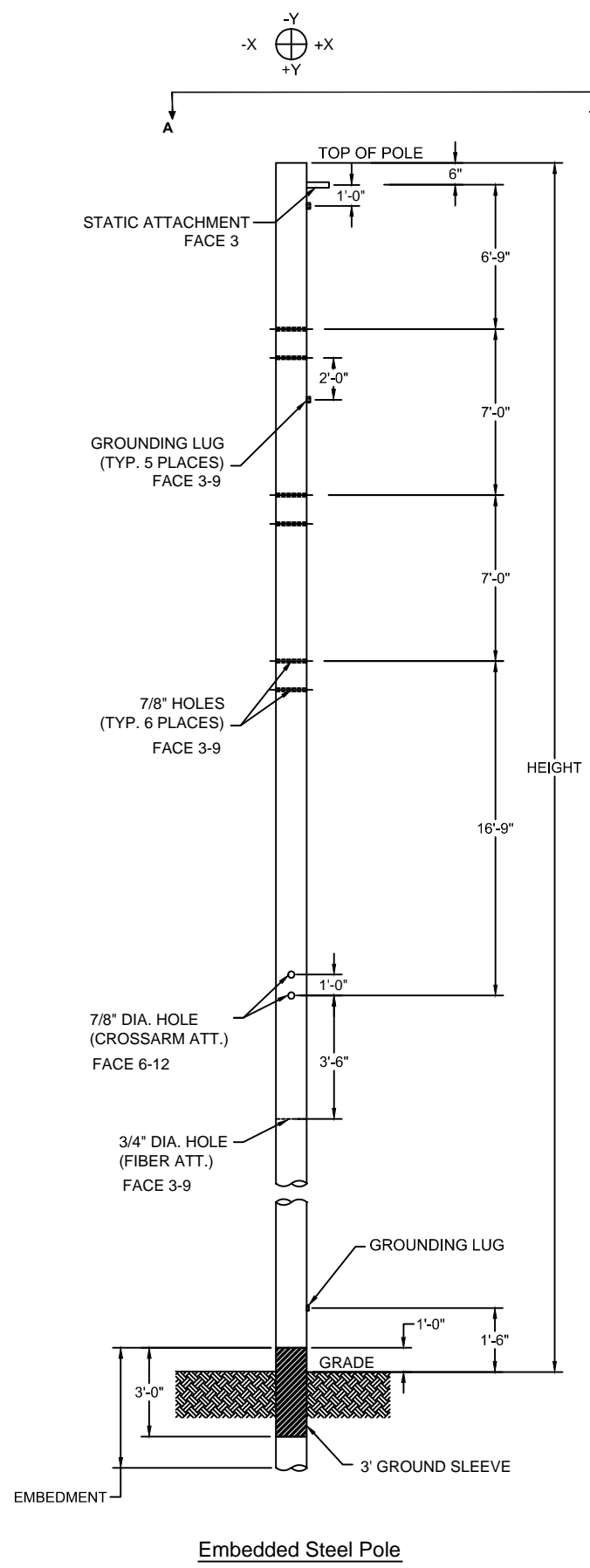

Embedded Steel Pole

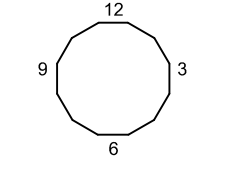

Section "A-A"

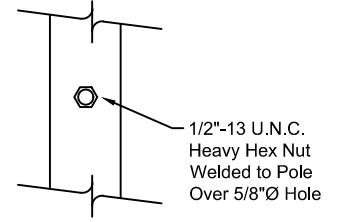

Grounding Lug Detail

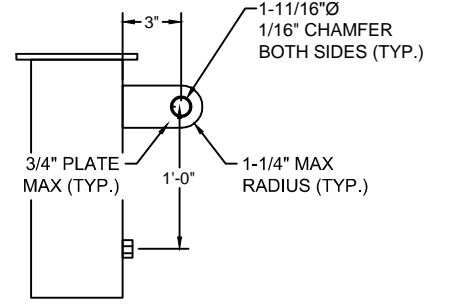

Static Attachment Detail

NOTES:

- FABRICATION TO STAMP, MARK, OR PUNCH THE 12 POSITION ON THE TOP AND BOTTOM OF EACH POLE SECTION AS AN AID TO CONSTRUCTION.
- THE STRUCTURE OUTLINE IS DIAGRAMMATIC ONLY AND NOT TO BE CONSIDERED RESTRICTIVE BEYOND GIVEN DIMENSIONS. GEOMETRIC SHAPES GIVEN IN THE DETAILS ARE ALSO NOT RESTRICTIVE.
- FABRICATOR SHALL PROVIDE JACKING NUT, 1" DIA., ALONG WITH PROCEDURE AND ASSEMBLY INSTRUCTIONS FOR SLIP JOINT. ANY SPECIAL TOOLING REQUIRED BY THE MANUFACTURE MUST BE PROVIDED.
- THE STRUCTURES SHALL BE DESIGNED IN ACCORDANCE WITH THE CURRENT EDITION OF THE NATIONAL ELECTRICAL SAFETY CODE (ANSI C2), THE LATEST REVISION OF THE ASCE REPORT ON "DESIGN OF STEEL TRANSMISSION POLE STRUCTURES" AND THE PROJECT SPECIFICATION.

Conductor Information				
Use	Type	Diameter	Wieght	Line Angle
Transmission	556.5 kcmil ACSR "Dove" 26/7	0.927 in.	0.0765 lbs/ft	0-6°
Distribution	477 kcmil ACSR "Pelican" 18/1	0.814 in.	0.0517 lbs/ft	0-6°
Static	3-#6 Alumaweld	0.349 in.	0.0178 lbs/ft	0-6°

NOTES	REV	DATE	BY	DESCRIPTION	REV	DATE	BY	DESCRIPTION	SCALE		<b>City of Rochelle, IL</b> Transmission Pole Replacement Steel Direct Embed Structure <small>BHMG ENGINEERS INC.          630 JEFFCO BOULEVARD          ARNOLD, MISSOURI 63010</small>	JOB NO.	REV.
									None			1521	1
									<small>DRAWN: JGM          DATE: 12/15/14          CHECKED: TWE          APPROVED: LCP</small>		REFERENCE	DRAWING NO.	
													TP-138D

Load Case	Load Case Description	Deflect Limit	Static Wire			Transmission Conductor						Distribution Conductor						Neutral Conductor								
			T <sub>SA</sub>	V <sub>SA</sub>	L <sub>SA</sub>	T <sub>SB</sub>	V <sub>SB</sub>	L <sub>SB</sub>	T <sub>TA</sub>	V <sub>TA</sub>	L <sub>TA</sub>	T <sub>TB</sub>	V <sub>TB</sub>	L <sub>TB</sub>	T <sub>DA</sub>	V <sub>DA</sub>	L <sub>DA</sub>	T <sub>DB</sub>	V <sub>DB</sub>	L <sub>DB</sub>	T <sub>NA</sub>	V <sub>NA</sub>	L <sub>NA</sub>	T <sub>NB</sub>	V <sub>NB</sub>	L <sub>NB</sub>
1	N.E.S.C. Heavy (250B) (1/2" Ice, 4 PSF Wind, 0° F)	N/A	0.36	0.55	-4.73	0.85	0.29	4.69	0.83	0.54	-5.73	2.11	0.62	11.67	0.71	0.27	-5.83	0.67	0.19	5.89	0.49	0.20	-2.93	0.67	0.19	5.89
2	N.E.S.C. Extreme Wind (250C) (0" Ice, 90 MPH Wind, 60° F)	N/A	0.26	0.18	-2.10	0.35	0.10	1.79	0.44	0.27	-2.38	1.01	0.26	4.64	0.34	0.09	-2.11	0.30	0.07	2.09	0.20	0.06	-1.03	0.18	0.45	1.04
3	N.E.S.C. Extreme Ice with Concurrent Wind (250D) (3/4" Ice, 40 MPH Wind, 15° F)	N/A	0.33	0.34	-2.89	0.53	0.30	3.03	0.49	0.45	-3.49	1.27	0.53	7.26	0.42	0.25	-3.62	0.39	0.18	3.58	0.26	0.19	-1.94	0.24	0.14	1.92
4	Normal Operating (0" Ice, No Wind, 60° F)	1.5%	0.17	0.17	-1.94	0.16	0.08	1.17	0.21	0.25	-1.80	0.46	0.27	3.00	0.10	0.10	-1.12	0.10	0.08	1.13	0.04	0.06	-0.41	0.04	0.05	0.41
5	Broken Conductor Ahead (1/2" Ice, 4 PSF Wind, 0° F)	N/A	0.00	0.00	0.00	0.85	0.29	4.69	0.00	0.00	0.00	2.11	0.62	11.67	0.00	0.00	0.00	0.67	0.19	5.89	0.00	0.00	0.00	0.67	0.19	5.89

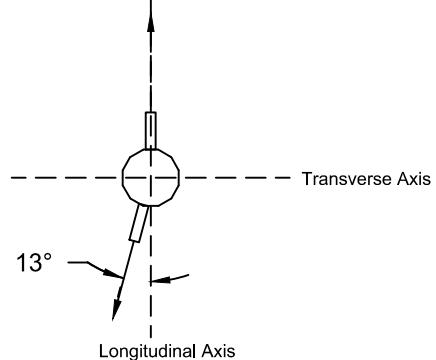

Static Plan View

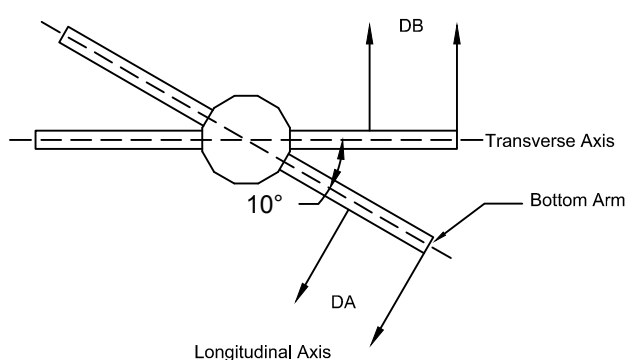

Distribution Plan View

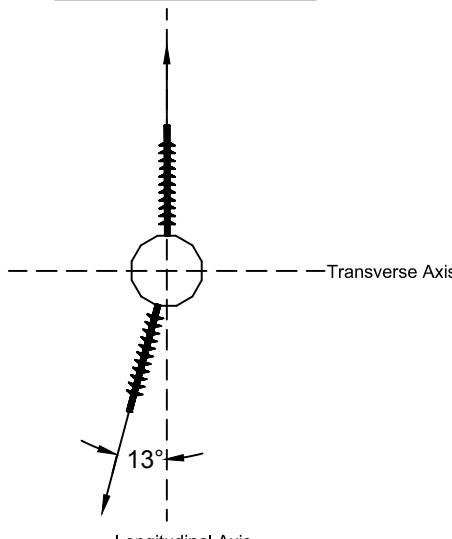

Transmission Plan View

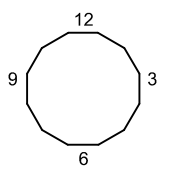

Section "A-A"

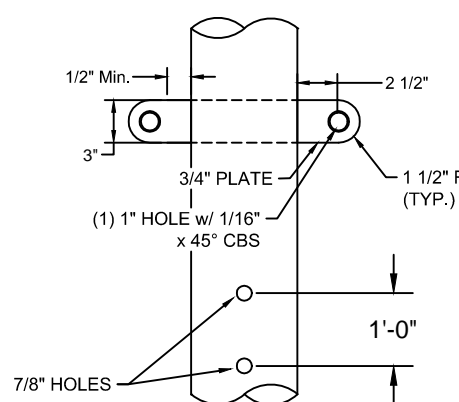

Detail "A"

Transmission Hole Spacing

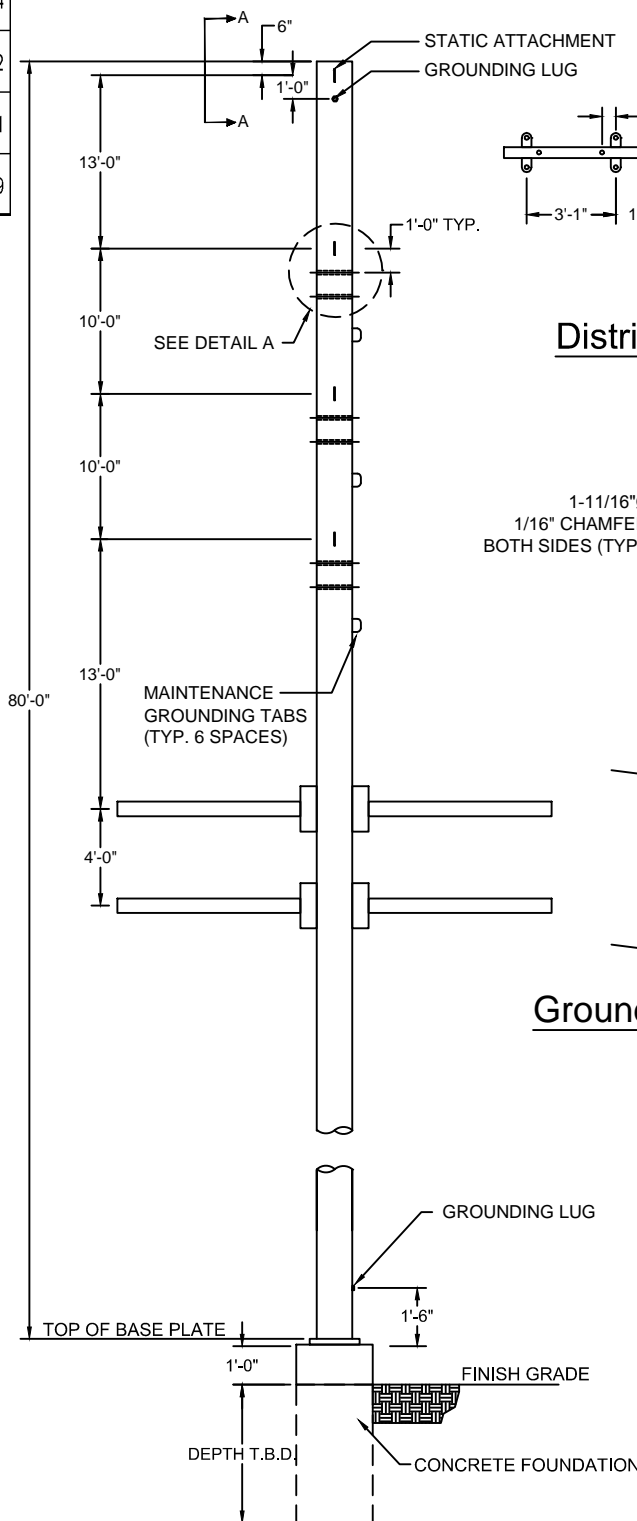

Typical Steel Pole With Concrete Foundation

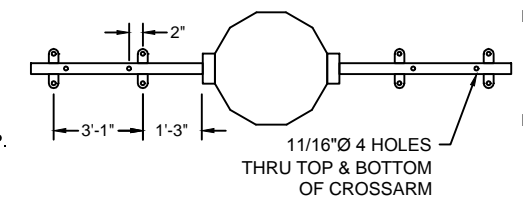

Distribution Arm Detail

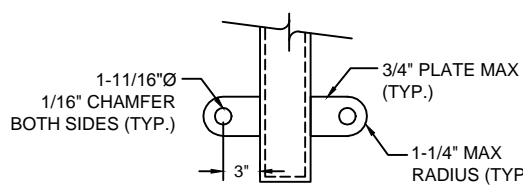

Section "B-B"

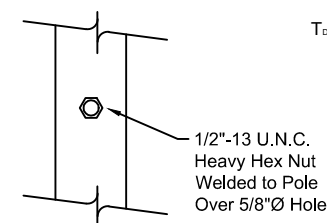

Grounding Lug Detail

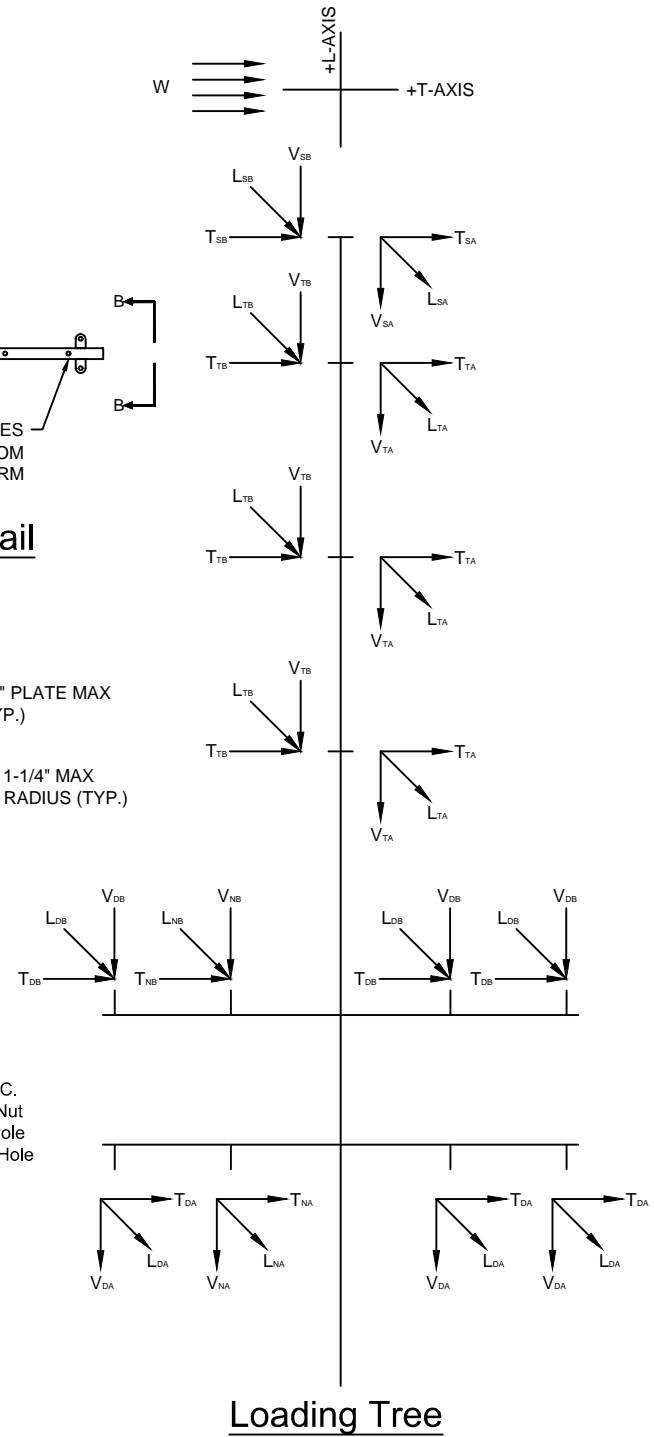

Loading Tree

Conductor Information				
Utility	Use	Type	Diameter	Weight
RMU	Transmission #1 (North)	556.5 kcmil ACSR "Dove" 26/7	0.927 in.	0.765 lbs/ft
RMU	Transmission #2 (South)	556.5 kcmil ACSR "Dove" 26/8	0.927 in.	0.765 lbs/ft
RMU	Distribution #1 (North)	477 kcmil ACSR "Pelican" 18/1	0.814 in.	0.517 lbs/ft
COM	Distribution #2 (South)	477 kcmil ACSR "Pelican" 18/1	0.814 in.	0.517 lbs/ft
RMU	Static #1 (North)	3-#6 Alumaweld	0.349 in.	0.178 lbs/ft
RMU	Static #2 (South)	3-#6 Alumaweld	0.349 in.	0.178 lbs/ft

- NOTES:
- FABRICATION TO STAMP, MARK, OR PUNCH THE 12 POSITION ON THE TOP AND BOTTOM OF EACH POLE SECTION AS AN AID TO CONSTRUCTION.
  - THE STRUCTURE OUTLINE IS DIAGRAMMATIC ONLY AND NOT TO BE CONSIDERED RESTRICTIVE BEYOND GIVEN DIMENSIONS. GEOMETRIC SHAPES GIVEN IN THE DETAILS ARE ALSO NOT RESTRICTIVE.
  - FABRICATOR SHALL PROVIDE JACKING NUT, 1" DIA., ALONG WITH PROCEDURE AND ASSEMBLY INSTRUCTIONS FOR SLIP JOINT. ANY SPECIAL TOOLING REQUIRED BY THE MANUFACTURE MUST BE PROVIDED.
  - THE STRUCTURES SHALL BE DESIGNED IN ACCORDANCE WITH THE CURRENT EDITION OF THE NATIONAL ELECTRICAL SAFETY CODE (ANSI C2), THE LATEST REVISION OF THE ASCE REPORT ON "DESIGN OF STEEL TRANSMISSION POLE STRUCTURES" AND THE PROJECT SPECIFICATION.

REV	DATE	BY	DESCRIPTION	REV	DATE	BY	DESCRIPTION
3	12/22/14	TWE	Change in Deflection Limits				
2	12/22/14	TWE	Add Load Condition				
1	12/16/14	TWE	Released for Pole RFP				

SCALE None  
 DRAWN JGM  
 DATE 12/8/14  
 CHECKED TWE  
 APPROVED LCP



**City of Rochelle, IL**  
 Transmission Pole Replacement  
 Self Supported Deadend Structure  
 BHM ENGINEERS INC.  
 630 JEFFCO BOULEVARD  
 ARNOLD, MISSOURI 63010  
 TELE: (636) 296-8600 FAX: (636) 296-8611

JOB NO.	REV.
1521	3
REFERENCE	DRAWING NO.
	STR. #03727

PLOT DATE: