

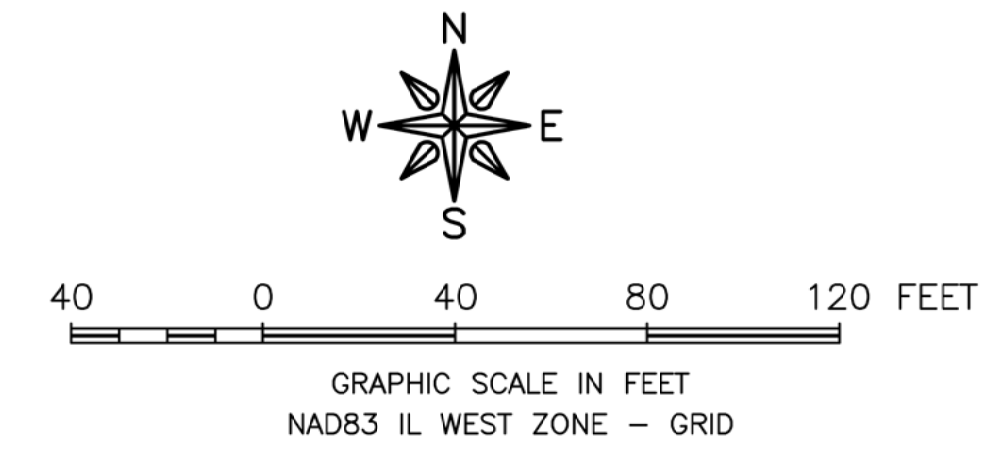









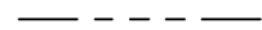

FINAL PLAT OF SUBDIVISION "FLAGG ROAD COMMONS - PHASE 2"

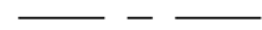
RE-SUBDIVISION OF LOT 1 AND 2, FLAGG ROAD COMMONS, PART OF NE 1/4 OF SECTION 13, T40N, R1E, 3RD P.M. CITY OF ROCHELLE, OGLE COUNTY, ILLINOIS

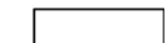
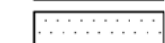

- LEGEND**
-  SECTION CORNER AS DESCRIBED
 -  PROPERTY LINE
 -  SECTION LINE
 -  EASEMENT LINE (EL)
 -  BUILDING SETBACK LINE (BSL)
 -  CENTERLINE ROAD
 -  RIGHT-OF-WAY
 -  RECORD INFORMATION
 -  UTILITY & DRAINAGE EASEMENT
 -  INGRESS/EGRESS & UTILITY EASEMENT
 -  SPECIAL FLOOD HAZARD EASEMENT
 -  FOUND EXISTING STAKE
 -  ROW MARKER
 -  100 YEAR BASE FLOOD ELEVATION 791.9' PER FIRM MAP NO 17141C0479E, NGVD 88

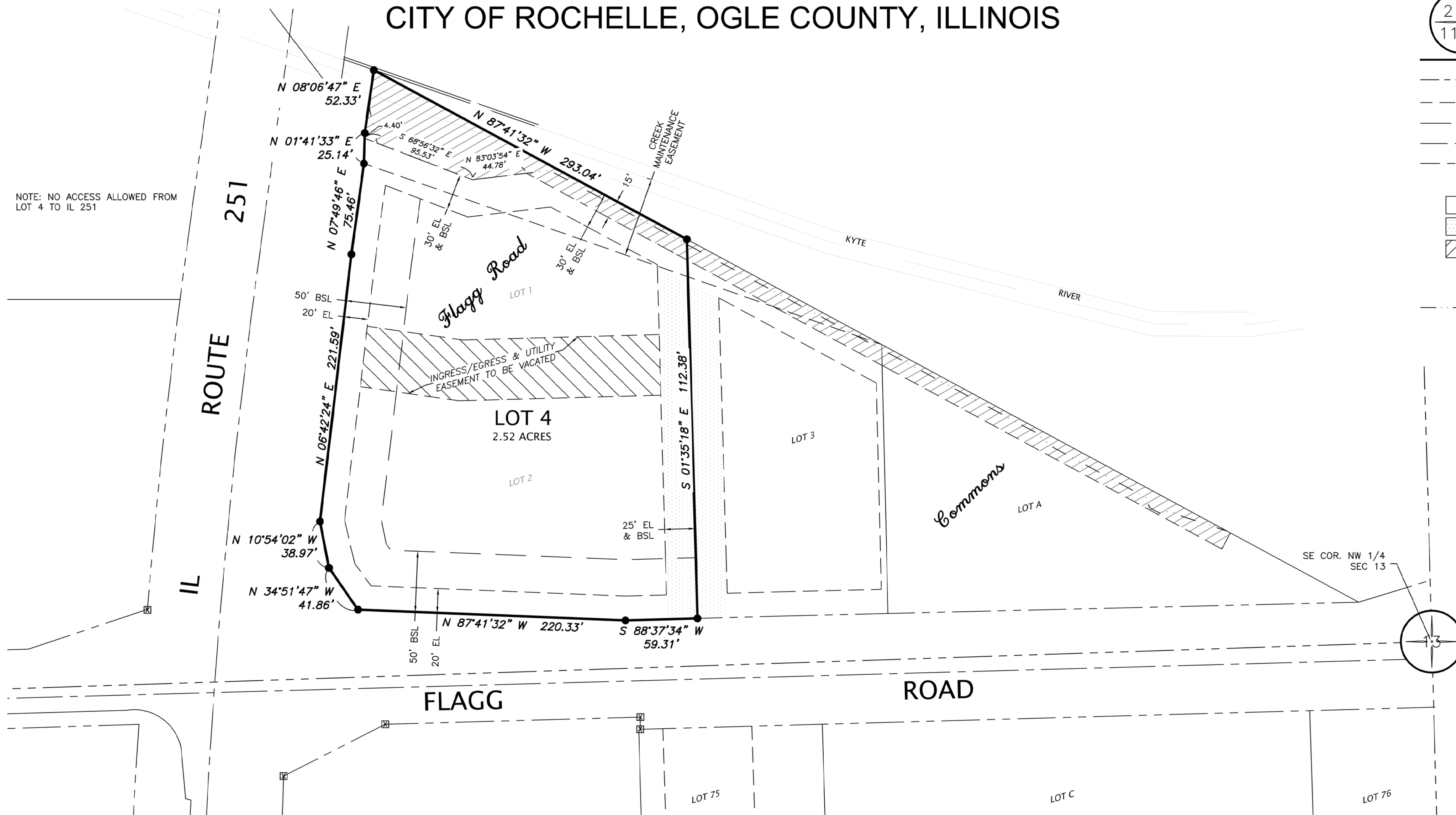

NOTE: NO ACCESS ALLOWED FROM LOT 4 TO IL 251

SURVEYOR'S CERTIFICATE

STATE OF ILLINOIS)
COUNTY OF OGLE) (SS

This is to certify that I, Scott I. Immel, an Illinois Professional Land Surveyor, have surveyed the following described property:

Lots One and Two of FLAGG ROAD COMMONS SUBDIVISION, being a part of the Northeast Quarter of Section 13, Township 40 North, Range 1 East of the Third Principal Meridian, County of Ogle, City of Rochelle, State of Illinois, as recorded in the Ogle County Recorder's Office.

as shown by the attached plat, which is a correct representation of said survey and subdivision. All distances are given in feet and decimal parts thereof.

I hereby certify that all of this Plat of FLAGG ROAD COMMONS - PHASE 2 is located within the Corporate Limits of the City of Rochelle.

I hereby also certify that part of this Plat of FLAGG ROAD COMMONS - PHASE 2 is located within a SPECIAL FLOOD HAZARD AREA as designated upon FIRM MAP NO 17141C0479E, but that all SPECIAL FLOOD HAZARD AREAS are contained in easements or on land granted to the City of Rochelle and that no part of the buildable area of all lots depicted on said Plat are located within said SPECIAL FLOOD HAZARD AREA.

Note: Per State of Illinois Survey Standards, all exterior subdivision corners have been set. Interior corners will be set with 5/8" diameter rebar prior to any conveyances or no later than one year after the recording of this plat.

Dated this 18th day of January, 2019, A.D. at the office of Fehr Graham, Rochelle, Illinois



Scott I. Immel, Illinois Professional Land Surveyor No. 35-3462
Current Expiration Date: November, 30, 2020

FEHR GRAHAM ILLINOIS
ENGINEERING & ENVIRONMENTAL IOWA
ILLINOIS DESIGN FIRM NO. 184-003525 WISCONSIN

515 LINCOLN HWY, ROCHELLE, IL 61068 P:815.562.9087

HAYDEN REAL ESTATE JOB NUMBER:
19-008

DATE: 03/06/2019 REVISED
FIELD WORK COMPLETED: ___/___/2017
FIELD: ___ DRAWN: T.J.L. QA/QC: S.H.

SHEET NUMBER:
1 of 2

FINAL PLAT OF SUBDIVISION
"FLAGG ROAD COMMONS - PHASE 2"
RE-SUBDIVISION OF LOT 1 AND 2, FLAGG ROAD COMMONS,
PART OF NE 1/4 OF SECTION 13, T40N, R1E, 3RD P.M.
CITY OF ROCHELLE, OGLE COUNTY, ILLINOIS

OWNER'S CERTIFICATE

STATE OF ILLINOIS)
 (SS
 COUNTY OF OGLE)

We, _____, Owners certify the lands there represented on the plat hereon, do certify that the said plat was prepared at our request and under our direction by, Scott I. Immel, Illinois Professional Land Surveyor for the firm of Fehr Graham. After said lands were duly surveyed by said surveyor, the corners of said lots were marked by substantial iron pins. The parts of the said lands described as streets are hereby dedicated to the City of Rochelle, for use as streets by the public in accordance with the laws of the State of Illinois, governing and controlling the dedication of and uses of ordinance adopted by the City of Rochelle, State of Illinois.

Dated this _____ day of _____, 20_____.

By: _____

NOTARY CERTIFICATE

STATE OF ILLINOIS)
 (SS
 COUNTY OF OGLE)

I, _____, a notary public, in and for said County, in the state

aforesaid, a notary public, do hereby certify that _____, personally known to me to be the same persons whose names are subscribed to the foregoing instrument as such owners, appeared before me this day in person and acknowledged that they signed and delivered the annexed plat as their own free and voluntary act for the uses and purposes therein set forth.

Given under my hand and Notarial Seal at _____, Illinois

this _____ day of _____, 20_____.

Notary Public (Seal)

My Commission Expires On _____

ENGINEER AND OWNERS DRAINAGE CERTIFICATE

STATE OF ILLINOIS)
 (SS
 COUNTY OF OGLE)

Pursuant to 765 ILCS 205/2; We hereby certify that to the best of our knowledge and belief, the drainage of surface water will not be changed by the construction of this subdivision or any part thereof, or that if such surface water drainage will be changed, adequate provision has been made for the collection and diversion of such surface water into water retention areas, public use areas, or drains which the subdivider has the right to use, and that such surface waters will not be deposited on the property of adjoining lands in such concentrations as may cause damage to the adjoining property because of the construction of the subdivision.

Dated this _____ day of _____, 20_____.

Professional Engineer: _____ (Seal)

Owner _____

SCHOOL DISTRICT CERTIFICATE

This is to certify that, to the best of my knowledge, the property described in the foregoing Surveyor's Certificate, which will be known as "FLAGG ROAD COMMONS - PHASE 2", is located within the boundaries of the following school districts

Rochelle High School Unit #212
 Rochelle Grade School Unit #231
 Kishwaukee College Unit #523

 (Owner)

CITY ENGINEER CERTIFICATE

STATE OF ILLINOIS)
 (SS
 COUNTY OF OGLE)

I, _____, do hereby certify that the required improvements have been installed, or the required guarantee bond has been posted for the completion of all required land improvements.

Dated at _____, Illinois, this _____ day of _____, 20_____.

 City Engineer: _____ (Seal)

License Number: _____

PLAN COMMISSION CERTIFICATE

STATE OF ILLINOIS)
 (SS
 COUNTY OF OGLE)

We, the undersigned members of the Plan Commission for the City of Rochelle, Illinois, hereby approve the Plat of "FLAGG ROAD COMMONS - PHASE 2" to the City of Rochelle as set forth above and hereon.

Given under our hands and seals this _____ day of _____, 20_____.

 President:

 Secretary:

CITY COUNCIL ACCEPTANCE RESOLUTION

STATE OF ILLINOIS)
 (SS
 COUNTY OF OGLE)

WHEREAS, _____, Owners of the land shown hereon have caused same to be subdivided and platted as shown, and, WHEREAS, the said land lies within the Corporate Limits of the City of Rochelle, Ogle County, Illinois.

NOW, THEREFORE, BE IT RESOLVED by the City Council of the City of Rochelle that the plat hereon be accepted and approved subject to the provisions of all applicable Ordinances of the City of Rochelle.

Passed this _____ day of _____, 20_____.

 City Clerk:

 Mayor:

COUNTY CLERK TAX CERTIFICATE

STATE OF ILLINOIS)
 (SS
 COUNTY OF OGLE)

I, _____, County Clerk of Ogle County, Illinois, do hereby certify that there are no delinquent general taxes, no unpaid forfeited taxes and no redeemable tax sales against any of the land included in the annexed plat. I further certify that I have received all statutory fees in connection with the annexed plat.

Given under my hand and seal at _____, Illinois,

this _____ day of _____, 20_____.

 County Clerk _____ (Seal)

CERTIFICATE AS TO SPECIAL ASSESSMENTS

STATE OF ILLINOIS)
 (SS
 COUNTY OF Ogle)

I do hereby certify that there are no delinquent or unpaid current or forfeited special assessments or any deferred installments thereof that have not been apportioned against the tract of land included in the plat.

Dated this _____ day of _____, 20_____.

at _____, Illinois.

 Collector of Special Assessments

COUNTY RECORDER'S CERTIFICATE

STATE OF ILLINOIS)
 (SS
 COUNTY OF OGLE)

Filed for record this _____ day of _____, 20_____.

at _____ o'clock in Book _____ of Plats, Page _____ and examined.

Microfilm Number _____.

Document Number _____.

 County Recorder

FEHR GRAHAM ILLINOIS
 ENGINEERING & ENVIRONMENTAL IOWA
 ILLINOIS DESIGN FIRM NO. 184-003525 WISCONSIN

515 LINCOLN HWY, ROCHELLE, IL 61068 P:815.562.9087

HAYDEN REAL ESTATE JOB NUMBER:
 19-008

DATE: 03/06/2019 REVISED FIELD WORK COMPLETED: ___/___/2017 SHEET NUMBER:
 FIELD: _____ DRAWN: T.J.L. QA/QC: S.H. 2 of 2